

AMICO

www.amico.org

Art Museum Image Consortium: museum multimedia for education

University of Pittsburgh
November 2, 1999

Jennifer Trant
Executive Director
jtrant@amico.org

What is AMICO?

- independent, non-profit, consortium of institutions with collections of art
- formed Sept. 1997
- 28+ members in North America
- new members welcome, world-wide
- **Mission: enable educational access to museum multimedia documentation**

Why AMICO?

- administer educational licensed efficiently
- create common library for consistency and ease of use
- encourage broad use of museum collections
- facilitate interchange of experience and ideas
- build links among museum and user community

Delivering the AMICO Library

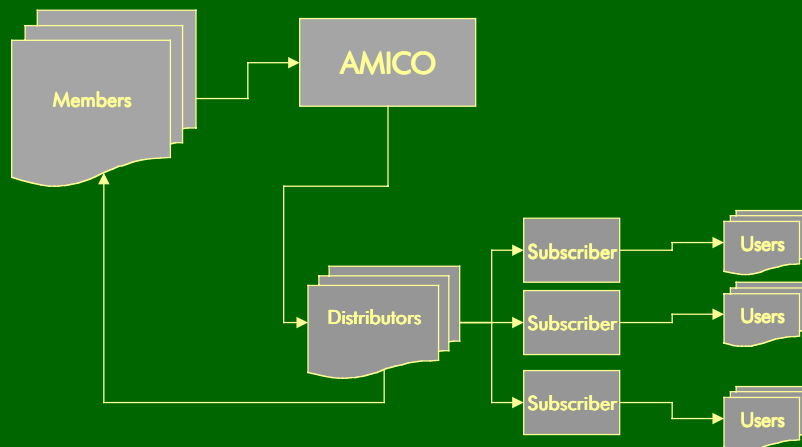

AMICO Members

Sept. 1999

- Albright-Knox Art Gallery
- Art Gallery of Ontario
- Art Institute of Chicago
- Asia Society Gallery
- Center for Creative Photography
- Cleveland Museum of Art
- Davis Museum and Cultural Center, Wellesley College
- The Detroit Institute of Arts
- Fine Arts Museums of San Francisco
- The Frick Collection and Art Reference Library
- International Museum of Photography, George Eastman House
- J. Paul Getty Museum
- Library of Congress
- Los Angeles County Museum of Art
- McMichael Canadian Art Collection
- The Metropolitan Museum of Art
- Minneapolis Institute of Arts
- Museum of Contemporary Art, San Diego
- Montreal Museum of Fine Arts
- Musée d'art contemporain de Montréal
- Museum of Fine Arts, Boston
- National Gallery of Canada
- National Museum of American Art
- Philadelphia Museum of Art
- San Francisco Museum of Modern Art
- San Jose Museum of Art
- Walker Art Center
- Whitney Museum of American Art

Interested in joining? see www.amico.org for full details ...

AMICO Members

- **pay dues**
 - \$2,000 - \$5,000 US based on budget
- **govern consortium**
 - committees: editorial, technical, rights, users
- **contribute to the shared Library**
 - text, image, multimedia
- **use the Library in their educational programs**
 - in galleries, library, research ...

AMICO Works

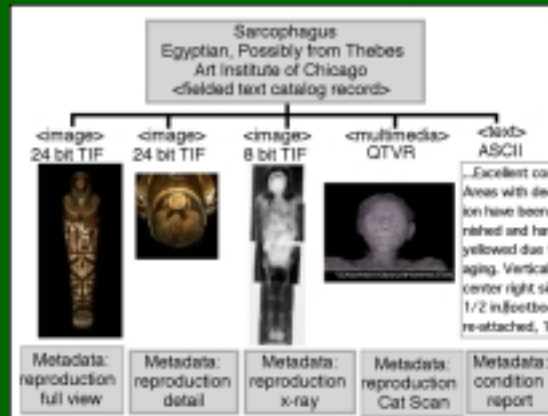

Works in the AMICO Library are documented by a catalog record, and image and an image metadata record. Other multimedia may also be included.

AMICO Distribution

- different Distributors for distinct communities
- Web Thumbnail Catalog for public access
- Research Libraries Group (RLG) provides university access
- State-wide access in Ohio, California (under development)
- Other Distributors for Primary & Secondary Schools, Public Libraries and international users

AMICO Web
www.amico.org



AMICO Web
Thumbnail
Catalog



Simple Search
www.amico.org

AMICO Web Thumbnail Catalog

Search Result

www.amico.org

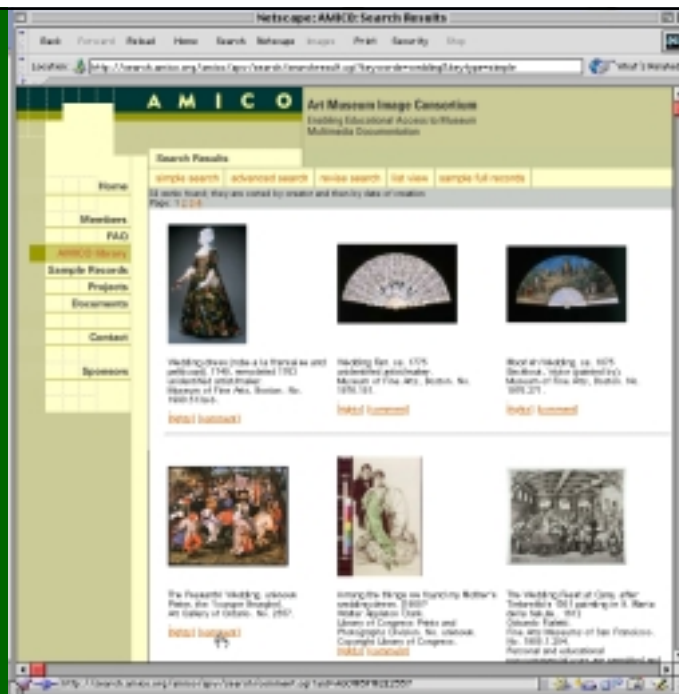

AMICO at RLG

- Research Libraries Group
 - not for profit library information network
- Offer online subscriptions to many resources
- AMICO Library part of their into Eureka Service
- Searchable like Bibliographic and Abstract & Index Databases
- Limited learning curve for existing users
- 24/7 support and service

AMICO
@
RLG

Subscription
Service

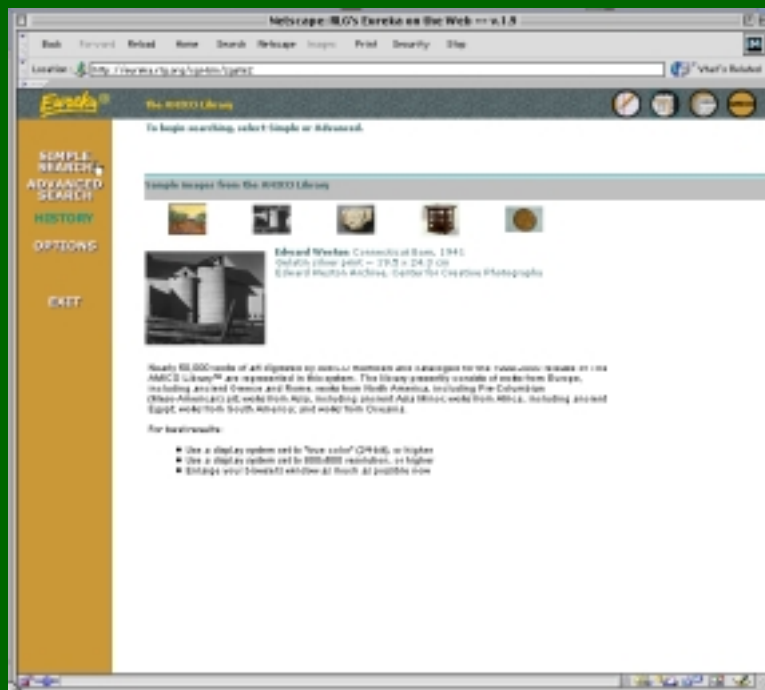

AMICO
@
RLG

Advanced
Search
Subscription
Service

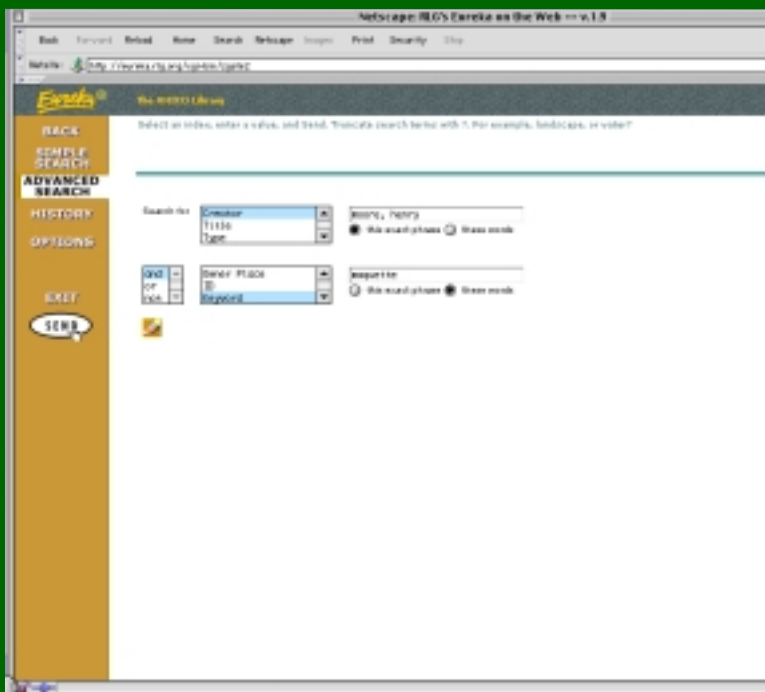

AMICO
@
RLG

Search
Result

Subscription
Service

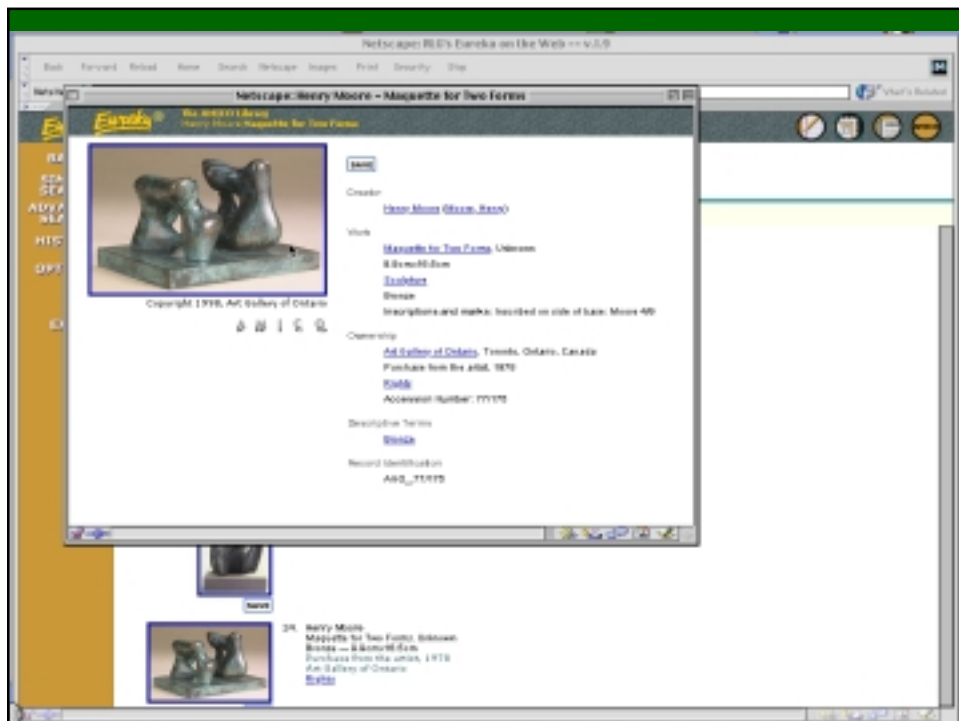
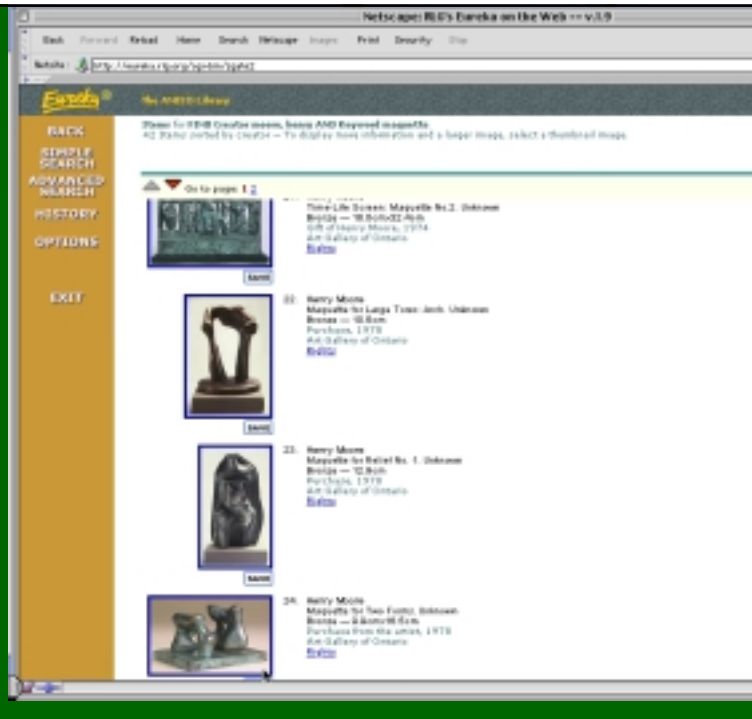

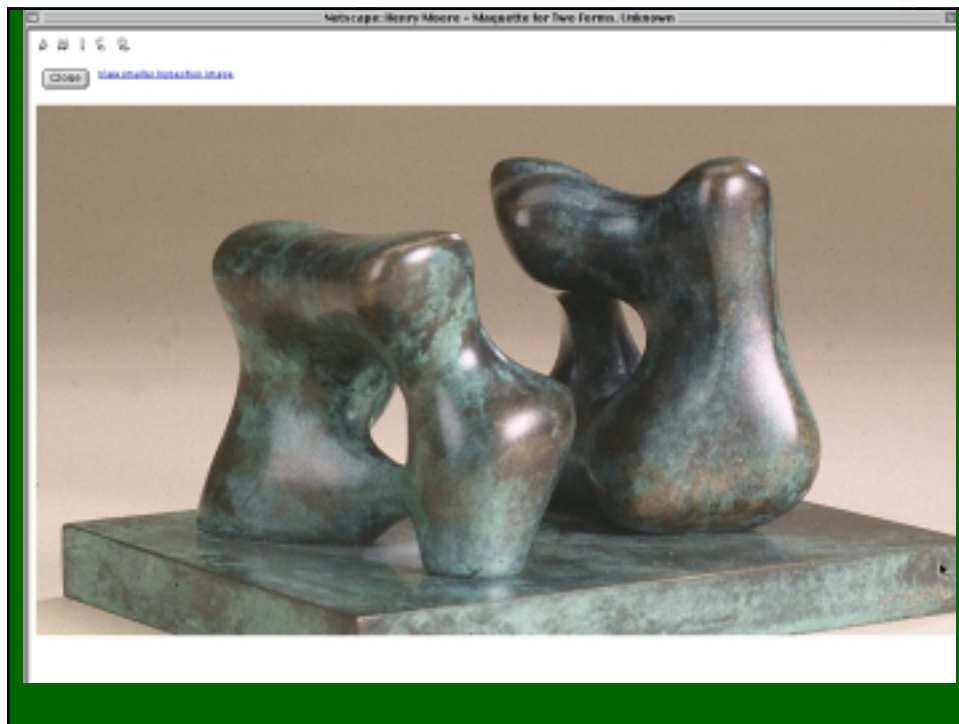

AMICO Subscribers

- **Educational Institutions license the compiled AMICO Library**
 - universities, colleges, schools, libraries, museums
- **Full range of users and uses, including:**
 - non-commercial, educational purposes
 - faculty, staff, students, researchers
 - walk-in users and distance education
 - use in presentations, papers, theses, lectures, local applications

AMICO in Art History Class



in depth study of one work



projection of images in classroom



Student assignments based on comparisons of works

AMICO in Art Studio Class

Assignment:

- Review the AMICO library for works that explore the concepts of solid and void.
- Analyse them as you prepare for the creation of your own work.

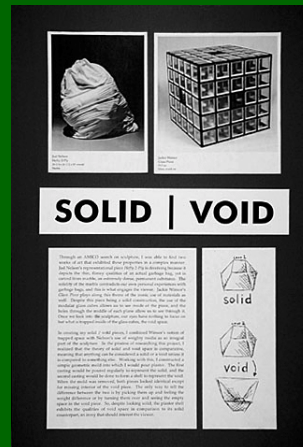

AMICO in the Library

online review
replaces slide
carrousel



AMICO in Cultural History

*Dürer's
Large Passion*
used with
*Bach's
St. Matthew Passion*
to provide context for
*Luther's
Freedom of a Christian*

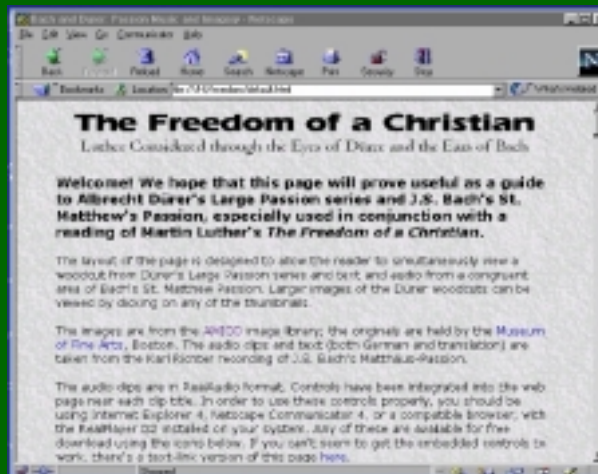

AMICO in Technical Studies

- **Computer Imaging**
 - Review metadata accompanying AMICO images and assess issues in image quality and fidelity
 - Identify criteria for creating accurate digital colour reproductions of works of art
- **School of Printing**
 - Assess issues in faithful colour reproduction from digital source

Issues

- **Content and Documentation**
- **Intellectual Property**
- **Economics**
- **Community Building**

AMICO's Role

- share, shape and standardize museum documentation
- create ongoing, self-supported, sustainable infrastructure
- enable educational access to museum multimedia

More info?

Art Museum Image Consortium
<http://www.amico.org>

info@amico.org

