

# AMICO

[www.amico.org](http://www.amico.org)

## Art Museum Image Consortium: a Cultural Digital Library for Educational Users

CIDOC/mda

September 9, 1999

**Jennifer Trant**  
Executive Director  
[jtrant@amico.org](mailto:jtrant@amico.org)

**David Bearman**  
Director, Strategy & Research  
[dbear@amico.org](mailto:dbear@amico.org)

# What is AMICO?

- independent, non-profit, consortium of institutions with collections of art
- formed Sept. 1997
- 28+ members in North America
- new members welcome, world-wide
  
- **Mission: enable educational access to museum multimedia documentation**

# AMICO Members

Sept. 1999

- Albright-Knox Art Gallery
- Art Gallery of Ontario
- Art Institute of Chicago
- Asia Society Gallery
- Center for Creative Photography
- Cleveland Museum of Art
- Davis Museum and Cultural Center, Wellesley College
- The Detroit Institute of Arts
- Fine Arts Museums of San Francisco
- The Frick Collection and Art Reference Library
- International Museum of Photography, George Eastman House
- J. Paul Getty Museum
- Library of Congress
- Los Angeles County Museum of Art
- McMichael Canadian Art Collection
- The Metropolitan Museum of Art
- Minneapolis Institute of Arts
- Museum of Contemporary Art, San Diego
- Montreal Museum of Fine Arts
- Musée d'art contemporain de Montréal
- Museum of Fine Arts, Boston
- National Gallery of Canada
- National Museum of American Art
- Philadelphia Museum of Art
- San Francisco Museum of Modern Art
- San Jose Museum of Art
- Walker Art Center
- Whitney Museum of American Art

Interested in joining? see [www.amico.org](http://www.amico.org) for full details ...

# AMICO Members

- **pay dues**
  - \$2,000 - \$5,000 US based on budget
- **govern consortium**
  - committees: editorial, technical, rights, users
- **contribute to the shared Library**
  - text, image, multimedia
- **use the Library in their educational programs**
  - in galleries, library, research ...

# AMICO Works

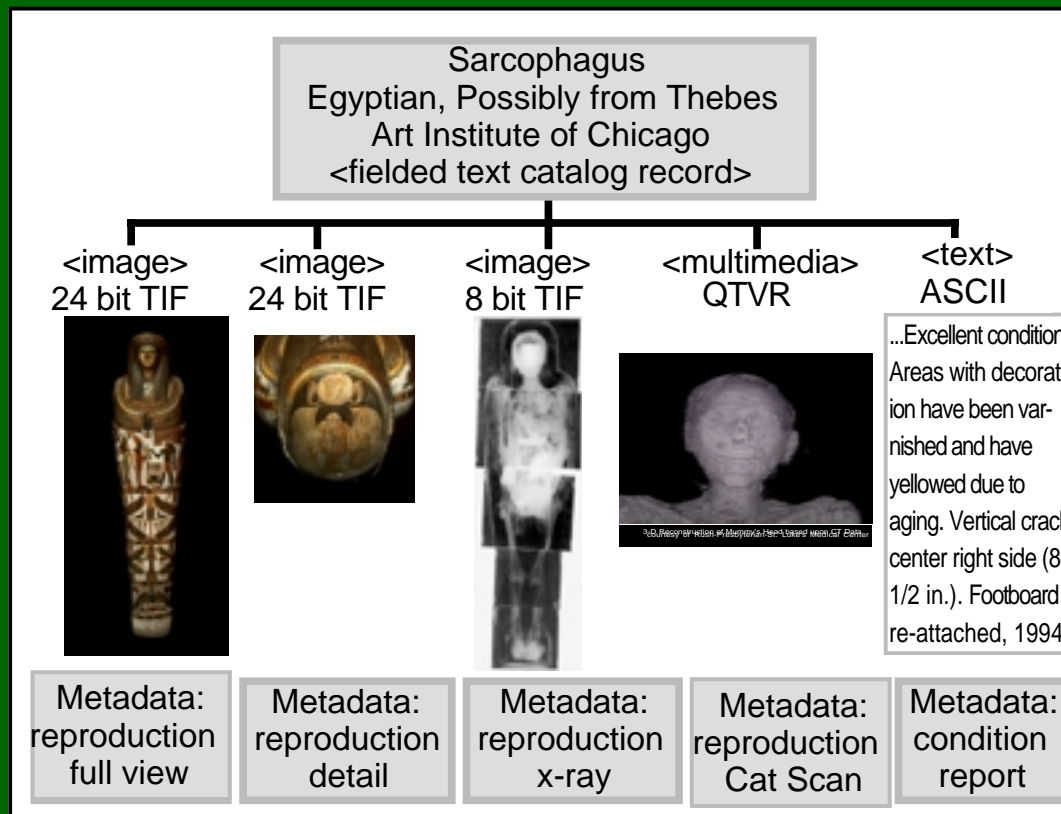

Works in the AMICO Library are documented by a catalog record, and image and an image metadata record. Other multimedia may also be included.

AMICO Web  
www.amico.org



Netscape: AMICO.org Home Page

Back Forward Reload Home Search Netscape Images Print Security Stop

Location: <http://www.amico.org/home.html>

**Home**  
Members  
FAQ  
**AMICO Library**  
Sample Records  
Projects  
Documents  
Contact  
Sponsors

**Art Museum Image Consortium**  
Enabling Educational Access to Museum  
Multimedia Documentation



Positions Available  
[Technical Director](#)    [Library Editor](#)  
Application Deadline:  
September 15, 1999

- Search the [Thumbnail Catalog](#) of the AMICO Library.
- View [Sample Records](#) from the AMICO Library.
- Learn how to [Participate in AMICO](#) as a Member, Subscriber, or Distributor.

The [1999 AMICO Library](#) is available.  
Check out the [Thumbnail Catalog](#) NOW with over 50,000 works of art!  
[Search of the Week](#)  
Criteria: Belgian (creator nationality) and 1800-1900 (creation date)

**Art Museum Network**  
The official website  
of the world's  
leading art museums

**The Art Museum Image Consortium (AMICO)** is a not for profit association of institutions with collections of art, that have come together to enable educational use of the digital documentation of their collections. Together, AMICO Members are building a joint digital library that is available to universities and colleges, public libraries, and kindergarten through 12th grade schools.

[Membership](#) in AMICO is open to all institutions with collections of works of art, willing to contribute to the AMICO Library.

**What's New ....**

- [AMICO and OhioLINK Reach An Agreement on Statewide Distribution of the AMICO Library](#)
- [AMICO Library now available.. Two new Members join the Consortium.](#)
- [AMICO held the University Testbed Research Meeting on June 3-4, 1999](#)
- [AMICO and the Artists Rights Society Agree: contemporary and modern works of art to be included in AMICO Library](#)

# AMICO Web Thumbnail Catalog

Simple Search

www.amico.org

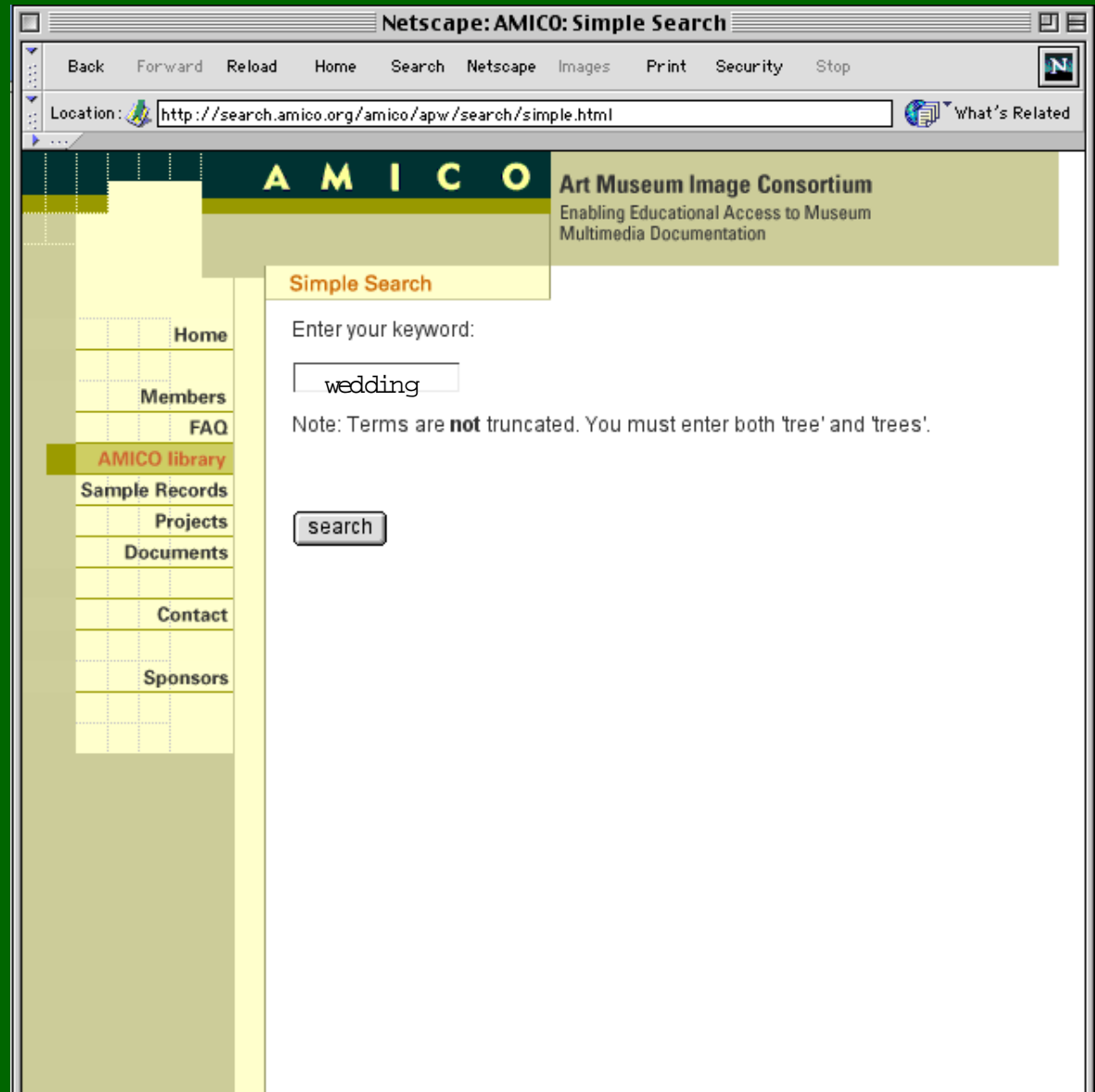

# AMICO Web Thumbnail Catalog

Search Result

www.amico.org

Netscape: AMICO: Search Results

Back Forward Reload Home Search Netscape Images Print Security Stop

Location: <http://search.amico.org/amico/apw/search/searchresult.cgi?keywords=wedding&keytype=simple> What's Related







## AMICO

Art Museum Image Consortium  
Enabling Educational Access to Museum  
Multimedia Documentation

### Search Results

[simple search](#) [advanced search](#) [revise search](#) [list view](#) [sample full records](#)

32 works found; they are sorted by creator and then by date of creation  
Page: 1 2 3 4

		
<p>Wedding dress (robe a la francaise and petticoat). 1740, remodeled 1763. unidentified artist/maker. Museum of Fine Arts, Boston. No. 1990.513a-b. <a href="#">rights</a> <a href="#">comment</a></p>	<p>Wedding Fan. ca. 1775 unidentified artist/maker. Museum of Fine Arts, Boston. No. 1976.181. <a href="#">rights</a> <a href="#">comment</a></p>	<p>Moorti Wedding. ca. 1875 Eeckhout, Victor (painted by). Museum of Fine Arts, Boston. No. 1976.271. <a href="#">rights</a> <a href="#">comment</a></p>
		
<p>The Peasants' Wedding. unknown Pieter, the Younger Brueghel. Art Gallery of Ontario. No. 2557. <a href="#">rights</a> <a href="#">comment</a></p>	<p>Among the things we found my Mother's wedding dress. [1905?] Walter Appleton Clark. Library of Congress Prints and Photographs Division. No. unknown. Copyright Library of Congress. <a href="#">rights</a> <a href="#">comment</a></p>	<p>The Wedding Feast at Cana, after Tintoretto's 1561 painting in S. Maria della Salute. 1612 Odoardo Fialetti. Fine Arts Museums of San Francisco. No. 1988.1.284. Personal and educational non-commercial uses are permitted and</p>

<http://search.amico.org/amico/apw/search/comment.cgi?aid=AG0%5F%2E2557>



# AMICO Web Thumbnail Catalog

Comments

www.amico.org

Netscape: AMICO: Comments

Back Forward Reload Home Search Netscape Images Print Security Stop

Location: <http://search.amico.org/amico/apw/search/comment.cgi?aid=AG0%5F%2E2557> What's Related

**A M I C O** Art Museum Image Consortium  
Enabling Educational Access to Museum  
Multimedia Documentation

Home  
Members  
FAQ  
**AMICO library**  
Sample Records  
Projects  
Documents  
Contact  
Sponsors

[Search Results](#)

Please feel free to leave your comments about this work:



The Peasants' Wedding, unknown Pieter, the Younger Brueghel.  
Art Gallery of Ontario, No. 2557.

Name:   
Email:   
Comments:

[rights](#) [comment](#)

# AMICO Web Thumbnail Catalog

Rights Links

www.amico.org

**Netscape: AMICO: Search Results**

Location: <http://www.ago.net/2/repro.htm>

**AMICO**

Home  
Members  
FAQ  
AMICO library  
Sample Records  
Projects  
Documents  
Contact  
Sponsors

**Search Results**

simple search advanced search

32 works found; they are sorted by  
Page: 1 2 3 4

Wedding dress (robe a la française, with petticoat). 1740, remodeled 18th century. Unidentified artist/maker. Museum of Fine Arts, Boston. 1990.513a-b.

[rights](#) [comment](#)

The Peasants' Wedding, unknown artist. Pieter the Younger Brueghel. Art Gallery of Ontario. No. 251.

[rights](#) [comment](#)

**Netscape: The Art Gallery of Ontario: Reproduction and Rights**

Location: <http://www.ago.net/2/repro.htm>

**REPRODUCTION AND RIGHTS**

Reproduction and Rights

Reproductions may not be made from colour photographs or 35mm slides.

The sale of photographs and loan of transparencies do not include reproduction permission for reproduction in any medium must be obtained from the Art Gallery of Ontario. Please apply in writing stating use of material and publication date. Before replacement, the conditions and terms as outlined in our Reproduction Rights Form must be used and prepayment for photographic materials must be made. The Reproduction Rights Form and pro-forma invoice are provided upon application to reproduce a work of art.

Reproduction fees are charged when a work of art is used for purposes similar to those of publishers and producers normally pay (i.e. designs, illustrations, photographs, etc.).

Fees are applied to reproductions when used for:

- Books, journals and magazines brochures, flyers and all advertising
- Large format reproductions for retail and wholesale markets, and for postcards, greeting cards, calendars, etc.
- Television, film, video, audio-visual presentations
- Digital imaging, CD-ROM, software and multi-media
- CD/cassette covers
- Packaging and products

The Art Gallery of Ontario may opt to take royalties in lieu of fee.

No fees are applied when reproductions used for:

- Magazines and periodicals or publications promoting the collection of the Art Gallery of Ontario
- Media releases for publicity promoting exhibitions of the Art Gallery of Ontario

Reproduction fees are applied in addition to the cost of photographic materials. Fees apply to one-time, one-language use in books, journals, magazines, catalogs and other publications. Fees may apply to multi-language or world rights use.

Black/white reproduction within body of text

Non-profit use - \$10

Commercial use - \$50

INFORMATION  
RESOURCES  
SERVICES

Search the  
EVENT CALENDAR

# AMICO Web Thumbnail Catalog

Advanced Search

www.amico.org

The screenshot shows a Netscape browser window titled "Netscape: AMICO: Advanced Search". The address bar contains the URL "http://search.amico.org/amico/apw/search/advanced/". The page header features the AMICO logo and the text "Art Museum Image Consortium" and "Enabling Educational Access to Museum Multimedia Documentation". A left-hand navigation menu includes links for Home, Members, FAQ, AMICO library (highlighted), Sample Records, Projects, Documents, Contact, and Sponsors. The main content area is divided into two sections: "A. Specify Search:" and "B. Choose Date Range:". Under "A. Specify Search:", there is a "Pick a field:" dropdown menu currently set to "Creation Date", a "Pick Terms" button, and a "Do Search" button. Under "B. Choose Date Range:", there are two input boxes containing "1960" and "1969", and "Select" and "Cancel" buttons. At the bottom, there is a "Search Criteria:" section with a "Search For:" input field and a "Find It:" section with a "Do Search" button. The browser's status bar at the bottom shows various icons and a taskbar.

# AMICO Web Thumbnail Catalog

Search Result

www.amico.org

Netscape: AMICO: Search Results

Back Forward Reload Home Search Netscape Images Print Security Stop

Location: <http://search.amico.org/amico/apw/search/searchresult.cgi?criteria=oct%3D1960%2C1969&keytype=advanced&> What's Related







## AMICO

Art Museum Image Consortium  
Enabling Educational Access to Museum  
Multimedia Documentation

### Search Results

[simple search](#) [advanced search](#) [revise search](#) [list view](#) [sample full records](#)

581 works found; they are sorted by creator and then by date of creation  
Page: [1](#) [2](#) [3](#) [4](#) [5](#) [6](#) [7](#) [8](#) [9](#) [10](#) [11](#) [12](#) [13](#) [14](#) [15](#) [16](#) [17](#) [18](#) [19](#) [20](#) [21](#) [22](#) [23](#) [24](#) [25](#) [26](#) [27](#) [28](#) [29](#) [30](#) [31](#) [32](#) [33](#) [34](#) [35](#) [36](#) [37](#) [38](#) [39](#) [40](#) [41](#) [42](#) [43](#) [44](#) [45](#) [46](#) [47](#) [48](#) [49](#) [50](#) [51](#) [52](#) [53](#) [54](#) [55](#) [56](#) [57](#) [58](#) [59](#) [60](#) [61](#) [62](#) [63](#) [64](#) [65](#)

		
<p>Winter Wall. 1962 Peter Agostini. Walker Art Center. No. 64.13. Copyright 1998 Walker Art Center. <a href="#">rights</a> <a href="#">comment</a></p>	<p>Bear/Bird Transformation. 1963 Latcholassie Akesuk. Art Gallery of Ontario. No. 90/145. Copyright 1998: Art Gallery of Ontario/L. Akesuk. <a href="#">rights</a> <a href="#">comment</a></p>	<p>Mother and Child. 1966 Latcholassie Akesuk. Art Gallery of Ontario. No. 96/1017. Copyright 1998: Art Gallery of Ontario/L. Akesuk. <a href="#">rights</a> <a href="#">comment</a></p>
		
<p>Mother and Children. 1959 c Paulusikotak Alaku. Art Gallery of Ontario. No. 90/609. Copyright 1998: Art Gallery of Ontario/A. Paulusikotak estate. <a href="#">rights</a> <a href="#">comment</a></p>	<p>Hunter with Walrus Head. 1955-1960 Aisa Qupirualu (Attributed to) Alasua. Art Gallery of Ontario. No. 96/572. Copyright 1998: Art Gallery of Ontario. <a href="#">rights</a> <a href="#">comment</a></p>	<p>Homage to the Square: Oasi. 1961 Josef Albers. Art Gallery of Ontario. No. 62/64. Copyright 1998: Art Gallery of Ontario. <a href="#">rights</a> <a href="#">comment</a></p>

# AMICO Web Thumbnail Catalog







Search Result

www.amico.org

Netscape: AMICO: Search Results

Back Forward Reload Home Search Netscape Images Print Security Stop

Location: <http://search.amico.org/amico/apw/search/searchresult.cgi?page=10&criteria=oct%3D1960%2C1969&keytype=s> What's Related

 <p>Model for The Spinner. 1966 Alexander Calder. Walker Art Center. No. 76.22. Copyright Artists Rights Society (ARS), New York. <a href="#">[rights]</a> <a href="#">[comment]</a></p>	 <p>Menuphar. 1968 Alexander Calder. National Museum of American Art, Smithsonian Institution. No. 1968.62.1. Copyright Artists Rights Society (ARS), New York. <a href="#">[rights]</a> <a href="#">[comment]</a></p>	 <p>Sculpture Three. 1962. 1962 Anthony Caro. Walker Art Center. No. 67.27. Copyright retained by the artist. <a href="#">[rights]</a> <a href="#">[comment]</a></p>
 <p>Georgiana. 1969-70 Anthony Caro, English, born 1924. Abright-Knox Art Gallery. No. K1970:13. <a href="#">[rights]</a> <a href="#">[comment]</a></p>	 <p>Root Monster. 1968 Miles B. Carpenter. National Museum of American Art, Smithsonian Institution. No. 1986.65.238. Requests for photographic material and permission to reproduce must be submitted in writing to: Registrar's Office, MRC 210, Rights &amp; Reproductions, National Museum of American Art, Smithsonian Institution, Washington, DC 20560. <a href="#">[rights]</a> <a href="#">[comment]</a></p>	 <p>Capri como. 1964 Andrea Casocella. Abright-Knox Art Gallery. No. 1966:3. <a href="#">[rights]</a> <a href="#">[comment]</a></p>

# AMICO at RLG

- Research Libraries Group (not for profit library information network)
- Online delivery of wide ranging resources via subscription
- AMICO Library integrated into Eureka Service
- Searchable like Bibliographic and Abstracting and Indexing Databases
- **No learning curve for existing users**
- 24/7 support and service

AMICO  
@  
RLG

Subscription  
Service

Netscape: RLG's Eureka on the Web -- v.1.9

Back Forward Reload Home Search Netscape Images Print Security Stop

Location: <http://eureka.rlg.org/cgi-bin/zgate2> What's Related

**Eureka**® The AMICO Library

To begin searching, select Simple or Advanced.

**SIMPLE SEARCH**  
ADVANCED SEARCH  
HISTORY  
OPTIONS  
EXIT

Sample images from the AMICO Library

**Edward Weston** Connecticut Barn, 1941  
Gelatin silver print — 19.5 x 24.3 cm  
Edward Weston Archive, Center for Creative Photography

Nearly 50,000 works of art digitized by AMICO members and cataloged for the 1999-2000 release of the AMICO Library™ are represented in this system. The library presently consists of works from Europe, including ancient Greece and Rome; works from North America, including Pre-Columbian (Meso-American) art; works from Asia, including ancient Asia Minor; works from Africa, including ancient Egypt; works from South America; and works from Oceania.

For best results:

- Use a display system set to "true color" (24-bit), or higher
- Use a display system set to 800x600 resolution, or higher
- Enlarge your browser's window as much as possible now

AMICO  
@  
RLG

Simple  
Search

The screenshot shows a Netscape browser window titled "Netscape: RLG's Eureka on the Web -- v.1.9". The address bar contains "http://eureka.rlg.org/cgi-bin/zgate2". The browser's menu bar includes "Back", "Forward", "Reload", "Home", "Search", "Netscape", "Images", "Print", "Security", and "Stop".

The main content area features the "Eureka® The AMICO Library" logo and a search prompt: "Type a few distinctive words. Example: **still life flowers**". A vertical navigation bar on the left contains the following options: "BACK", "SIMPLE SEARCH" (highlighted), "ADVANCED SEARCH", "HISTORY", "OPTIONS", "EXIT", and "SEND" (with a mouse cursor over it).

The search interface includes a dropdown menu with "Creator", "Title", and "Keyword" (selected). A text input field contains the word "mummy". Below the input field is a small icon of a pencil and eraser.



AMICO  
@  
RLG

Search  
Result

Netscape: RLG's Eureka on the Web -- v.1.9

Back Forward Reload Home Search Netscape Images Print Security Stop

Location: <http://eureka.rlg.org/cgi-bin/zgate2>

**Eureka®** The AMICO Library

**Items for FIND Keyword mummy**  
36 Items sorted by creator — To display more information and a larger image, select a thumbnail image.

▲ ▼ Go to page: [1](#) [2](#)

Sort result by: [Creator](#), [Title](#), [Date](#), or [Owner](#)

- 

1. Egypt, Akhmim (?), Early Roman Empire, 30 BC-AD 395  
Mummy Case  
30 BC-AD395  
Cartonage — Overall:  
Gift of the John Huntington Art and Polytechnic Trust  
Cleveland Museum of Art  
[Rights](#)

SAVE
- 

2. Egypt, Hawara, Roman Empire, early 2nd century AD  
Funerary Portrait of a Young Girl. 100-200  
Encaustic on wood — Overall: 39.4cm x 17.4cm  
John L. Severance Fund  
Cleveland Museum of Art  
[Rights](#)

SAVE
- 

3. Egypt, Roman Empire, early 2nd century AD  
Funerary Portrait of a Woman. 100-125  
Encaustic on linen — Overall: 25cm x 19.6cm  
John L. Severance Fund  
Cleveland Museum of Art  
[Rights](#)

SAVE

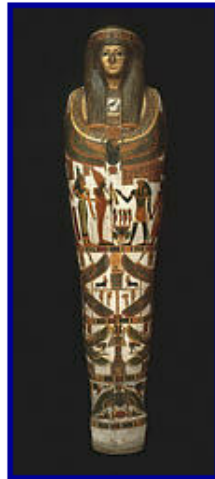

Copyright The Art Institute of Chicago, 1998

AMICQ

Other Views



Front view, photo of x-ray



View of top of head

Creator

[Egyptian](#)

Ancient Egypt Africa, North Africa, Egypt

Work

[Mummy Case of Paankhenamun](#), Europe, Greece, Central Greece and Euboea, Boeotia department, Thebes, Third Intermediate Period, Dynasty 22, c. 945 - 715 B.C.

H: 170.2 cm (67 in.); W: 43.2 cm (17 in.); D.: 31.7 cm (12-1/2 in.)

[Other](#)

Cartonnage (gum, linen, and papyrus), gold leaf, pigment

Inscriptions and marks: The hieroglyphic text above Horus reads: A royal offering of Osiris, presider over the West, the great god, lord of Abydos, Wennofer, ruler of Eternity. Utterance by Horus, the son of Osiris, the great god, lord of the sky; may he give a mortuary offering of food and viands, oxen and geese, incense, clothing and every good and pure thing for Osiris, the doorkeeper of the estate of Amun, Paankhenamun, deceased, son of Ainka, the doorkeeper of the estate of Amun, deceased, son of Ankhefenkhonsu. Paankhenamun means "The one who lives for Amun". Khamaat means "The one who arises in Truth." Ankhefenkhonsu means "He who lives for Khonsu". Other identifying hieroglyphs elsewhere on case.

Ownership

[The Art Institute of Chicago](#), Chicago, IL

The Art Institute of Chicago, William M. Willner Fund

[Rights](#)

Accession Number: 1910.238

Commentary

Subjects: Anthropoid coffin made for Paankhenamun, a doorkeeper of the estate of Amun in Thebes. The case is

What's Related



W: 43.2 cm (17

W>: 33.3 cm

Browser interface including Netscape window title, address bar, back button, sidebar with 'Eureka' logo, and a taskbar at the bottom with various system icons.



Accession Number: 1910.238



Copyright The Art Institute of Chicago, 1998

AMICQ

#### Commentary

**Subjects:** Anthropoid coffin made for Paankhenamun, a doorkeeper of the estate of Amun in Thebes. The case is decorated with a variety of images associated with rebirth. The central scene depicts the presentation of the deceased by the falcon-headed deity Horus to Osiris, main deity of the afterlife. Decoration on the mummy case: 1. Top register (head to middle of case). (neck area): Maat with a phoenix bird. "Broad collars": layers of floral necklaces. Beetle with hawk head below the sun disk; wings of Nut. Under beetle: Shen: hieroglyph for "eternity." 2. Middle top register: Scene of Paankhenamun with the gods. Proper left: Paankhenamun with a cone of scented fat on his wig, is led into the presence of the gods. Next to Paankhenamun: The hawk-headed god, Horus, Son of Osiris. Center figure holding staff: The god Osiris. Next to Osiris: Isis, the sister of Osiris. Proper far right: Nephthys, sister of Osiris. Center: The Four Sons of Horus. 3. Middle lower register. The geographic symbol of the city of Abydos. Proper left: Winged deity, Hathor. Proper right: Winged deity, Maat. Rams on a standard. Under left ram: A (mummy/tekenu ?) bundle on a standard. Under right ram: Double plumed headdress. 4. Bottom Register. Center: Djed pillar. Facing pillar: Falcon gods, "The Behdite, Lord of Heaven." Under wings: Eyes of Horus. 5. Foot register. Center: Winged scarab. Eyes of Horus. Above beetle: Shen: hieroglyph for "eternity." Above wings: Demons who live in the underworld. 6. The back of the coffin: single large djed pillar. On either side, below its elbows: hieroglyphs for "The West."

**Context:** Egyptian, probably from Thebes. The coffin belonged to a man named Paankhenamun, whose name translates as "He Lives for Amun." Paankhenamun was the doorkeeper of the temple of the god Amun, a position he inherited from his father. X-rays reveal that he was approximately 5' 6" tall and died in middle age. Cartonnage cases were popular at the time that Paankhenamun was buried. After mummification, the wrapped body was inserted into the case through the back. The back was then laced up, a footboard was added, and the case was painted. Cartonnage cases were normally placed inside one or more nested wooden coffins that were also decorated. The mummy case was x-rayed in 1985. The mummy case was cat-scanned and x-rayed in 1996.

#### Related Materials

**Multi media:** [3-D construction of mummy's head based upon CT data](#)

#### Descriptive Terms

[Ancient art](#)  
[Mummy Goods](#)  
[Mummy Goods](#)  
[Ancient Art](#)  
[European Decorative arts](#)

#### Record Identification

AIC\_1910.238



Accession Number: 1910.238



Commentary

Subjects: Anthropoid coffin made for Paankhenamun, a



3-D Reconstruction of Mummy's Head based upon CT Data  
courtesy of Rush-Presbyterian-St. Luke's Medical Center

case is  
rebirth. The  
eased by the  
the  
register (head to  
bird. "Broad  
nk head below  
eroglyph for  
enamum with  
e of scented fat  
ext to  
on of Osiris.  
Osiris: Isis, the  
Osiris. Center:  
The geographic  
deity, Hathor.  
ard. Under left  
Under right ram:  
nter: Djed pillar.  
Heaven." Under  
ed scarab. Eyes  
nity." Above  
back of the  
ow its elbows:

fin belonged to  
ates as "He  
ber of the  
rom his father.  
and died in  
e time that  
the wrapped  
The back was  
se was painted.  
e or more  
he mummy  
atscanned and

What's Related



W: 43.2 cm (17

W>: 33.3 cm

Related Materials

Multimedia: [3-D construction of mummy's head based upon CT data](#)

Descriptive Terms

- [Ancient art](#)
- [Mummy Goods](#)
- [Mummy Goods](#)
- [Ancient Art](#)
- [European Decorative arts](#)

Record Identification

AIC\_1910.238

AMICO  
@  
RLG

Advanced  
Search

Netscape: RLG's Eureka on the Web -- v.1.9

Back Forward Reload Home Search Netscape Images Print Security Stop

Netsite: <http://eureka.rlg.org/cgi-bin/zgate2>

**Eureka®** The AMICO Library

Select an index, enter a value, and Send. Truncate search terms with ?. For example, landscape, or water?

**BACK**  
**SIMPLE SEARCH**  
**ADVANCED SEARCH**  
**HISTORY**  
**OPTIONS**  
**EXIT**  
**SEND**

Search for

Creator  
Title  
Type

moore, henry

this exact phrase  these words

and  
or  
not

Owner Place  
ID  
Keyword

maquette

this exact phrase  these words



AMICO  
@  
RLG

Search  
Result

Netscape: RLG's Eureka on the Web -- v.1.9

Back Forward Reload Home Search Netscape Images Print Security Stop

Netsite: <http://eureka.rlg.org/cgi-bin/zgate2>

**Eureka®** The AMICO Library

**Items for FIND Creator moore, henry AND Keyword maquette**  
42 Items sorted by creator – To display more information and a larger image, select a thumbnail image.

Go to page: 1 2

 Time-Life Screen: Maquette No.2. Unknown  
Bronze — 18.0cmx32.4cm  
Gift of Henry Moore, 1974  
Art Gallery of Ontario  
[Rights](#)

**SAVE**

 22. Henry Moore  
Maquette for Large Torso: Arch. Unknown  
Bronze — 10.5cm  
Purchase, 1978  
Art Gallery of Ontario  
[Rights](#)

**SAVE**

 23. Henry Moore  
Maquette for Relief No. 1. Unknown  
Bronze — 12.9cm  
Purchase, 1978  
Art Gallery of Ontario  
[Rights](#)

**SAVE**

 24. Henry Moore  
Maquette for Two Forms. Unknown  
Bronze — 9.9cmx16.5cm  
Purchase from the artist, 1978  
Art Gallery of Ontario  
[Rights](#)



BA  
SIM  
SEA  
ADVA  
SEA  
HIS  
OPT  
E



Copyright 1998, Art Gallery of Ontario

A M I C O

SAVE

Creator

[Henry Moore \(Moore, Henry\)](#)

Work

[Maquette for Two Forms](#), Unknown

9.9cmx16.5cm

[Sculpture](#)

Bronze

Inscriptions and marks: Inscribed on side of base: Moore 4/9

Ownership

[Art Gallery of Ontario](#), Toronto, Ontario, Canada

Purchase from the artist, 1978

[Rights](#)

Accession Number: 77/175

Descriptive Terms

[Bronze](#)

Record Identification

AGO\_77/175



SAVE



- 24. Henry Moore  
Maquette for Two Forms. Unknown  
Bronze — 9.9cmx16.5cm  
Purchase from the artist, 1978  
Art Gallery of Ontario  
[Rights](#)





△ M I E Q

Close

[View smaller inspection image](#)





# AMICO in Art History Class



*in depth study of  
one work*



*projection of  
images  
in classroom*



*Student assignments based  
on comparisons of works*

# AMICO in Art Studio Class

## Assignment:

- *Review the AMICO library for works that explore the concepts of solid and void.*
- *Analyse them as you prepare for the creation of your own work.*

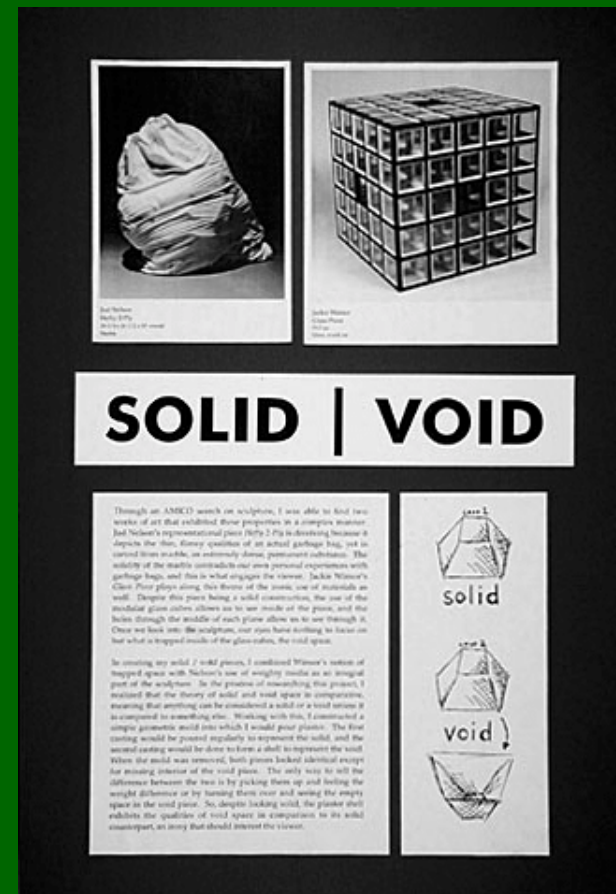

# AMICO in the Library

*online review  
replaces slide  
carrousel*



The screenshot shows a web browser window displaying the AMICO Project Images website. The browser's address bar shows the URL: [http://www.amico-images/19th/goya\\_pir.html](http://www.amico-images/19th/goya_pir.html). The website header features the AMICO logo and the URL <http://www.amn.org>. Below the header, a notice states: "These images are available only to members of the Boston College community, subject to the restrictions of the **AMICO license agreement**. All images copyright Art Museum Image Consortium, created under license by the Research Libraries Group, Inc."

The main content area is titled "Francesco Jose de Goya y Lucientes - Spanish Romantic Painter and Printmaker". It displays two artworks:

- The Ladies-in-waiting (Las Meninas).** 1778-9. After the painting by Velazquez (Prado 1174). Etching, lavis over sulfur bnt and/or crayon manner, drypoint, bunn and roulette; working proof — 405 x 325 mm. 1951 Purchase Fund. Museum of Fine Arts, Boston.
- Self-Portrait with Dr. Arrieta.** 1820. Oil on canvas — H.45-1/2 x W.31-3/8 in. The Ethel Morrison Van Derlip Fund. The Minneapolis Institute of Arts. Permission for educational use only granted by The Minneapolis Institute of Arts. Rights.

The browser window also shows a "Document: Done" status bar and various navigation icons.





# AMICO in Cultural History

*Dürer's  
Large Passion*

used with

*Bach's  
St. Matthew Passion*

to provide context for

*Luther's  
Freedom of a Christian*

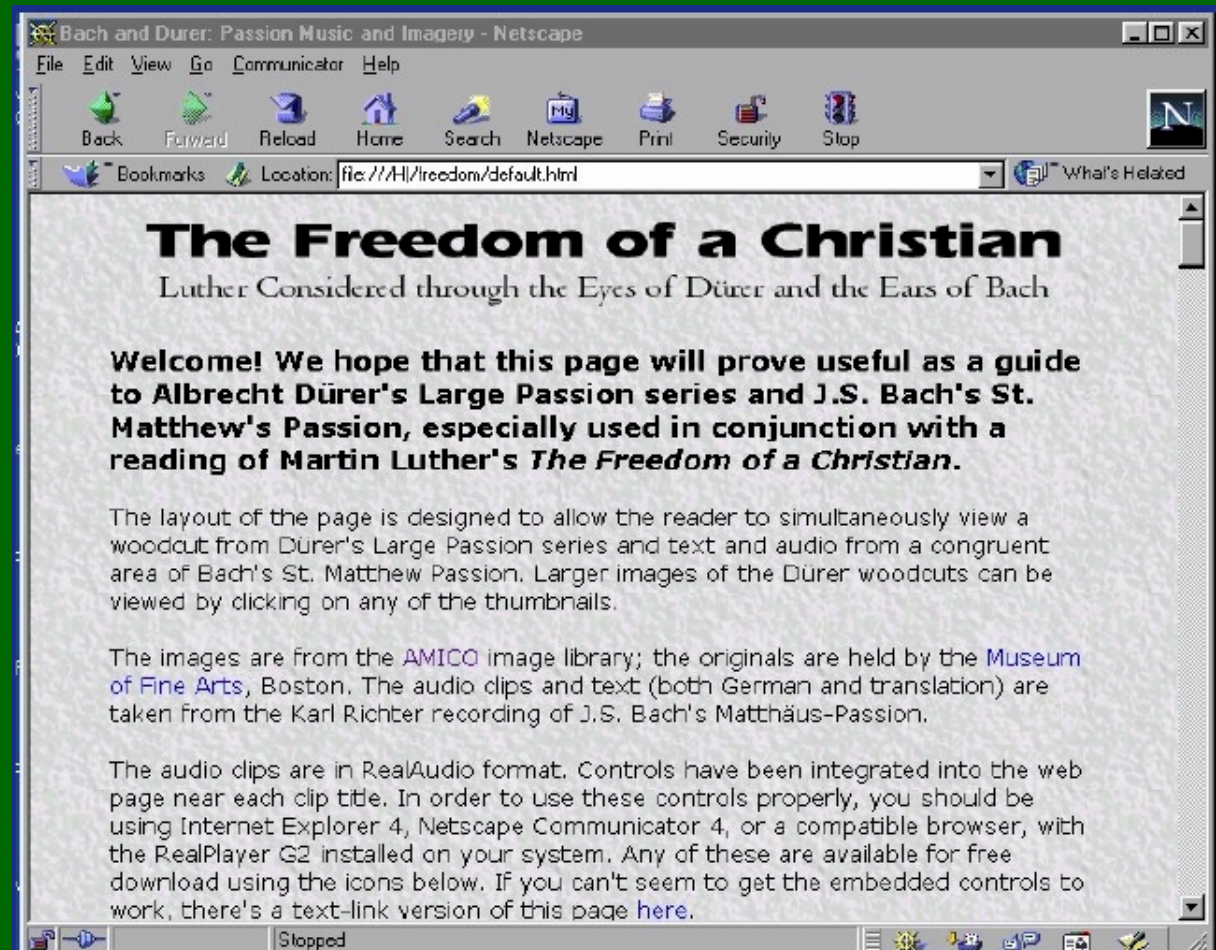

# AMICO in Technical Studies

- **Computer Imaging**
  - Review metadata accompanying AMICO images and assess issues in image quality and fidelity
  - Identify criteria for creating accurate digital colour reproductions of works of art
- **School of Printing**
  - Assess issues in faithful colour reproduction from digital source

# Issues: Documentation

- **data specification**
  - separate display data from access data
  - field level guidelines (for indexing dates, terms)
- **editorial consistency**
  - shared authority files and indexing rules
  - existing tools aren't enough (~30% of Names not in ULAN)
- **multimedia delivery**
  - common formats, structures, metadata and descriptions
  - persistent naming, to enable linking and navigation
- **cross-resource discovery**
  - integrate AMICO Library with other resources
  - e.g. bibliography and full texts

# Delivering the AMICO Library

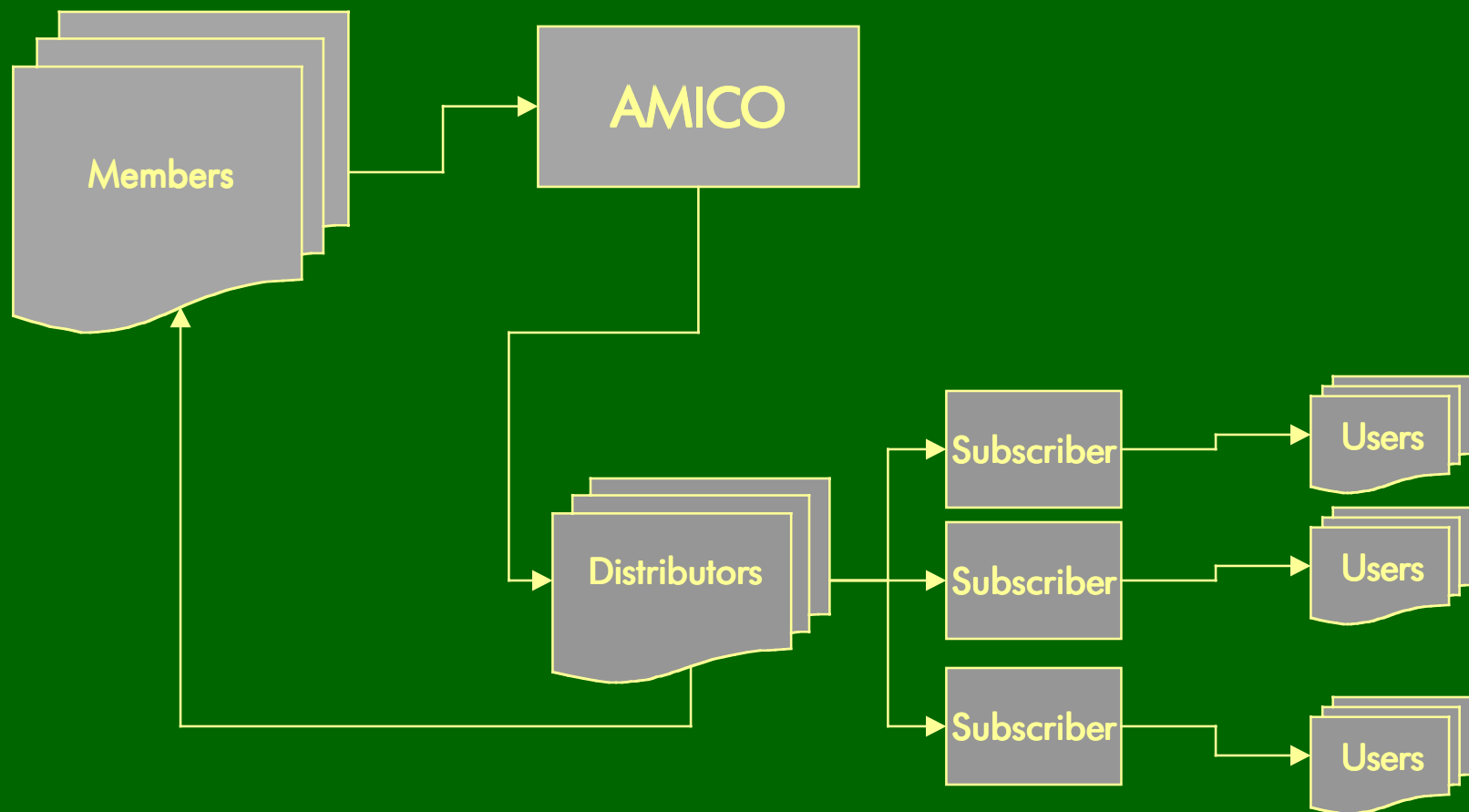

# Issues: Rights

- **consistent terms and conditions for all works in Library**
  - common agreement for all members
  - no special terms
- **distinct licenses for different user communities**
  - primary school uses different from university
- **international licenses**
  - global distribution requires review of terms
  - relationships between institutions and users differ
- **artists rights**
  - ARS in North America, others elsewhere



# Issues: Economics

- **self supporting not-for-profit**
  - cost-recovery required
  - not dependent on grant funding for core activities
  - long-term sustainability a key goal
- **all institutional participants have financial stake**
  - no money returned to members
  - subscription fees support the new activities of the consortium
  - incentives for distributors and subscribers to develop tools and add value
- **access remains free at point of use**

# Issues: Community Building

- **not-for-profit and educational focus**
  - no commercial players
- **consistent terms for participants**
  - common, transparent, formula-based agreements
- **open multi-way communications**
  - public specifications: technical and data
  - known license terms
- **shared risks and benefits**
  - members collaborate online
  - users share experiences

# Access to the AMICO Library

- different Distributors for different markets
- public access to Thumbnail Catalog on web
- university access provided by Research Libraries Group (RLG)
- state-wide distributors in Ohio, California (under development)
- seeking other Distributors to serve Primary and Secondary Schools and Public Libraries

# Why AMICO?

- share, shape and standardize museum documentation
- ongoing, self-supported and sustainable infrastructure
- enable educational access to museum multimedia

# More info?

Art Museum Image Consortium  
<http://www.amico.org>

[info@amico.org](mailto:info@amico.org)

The screenshot shows a Netscape browser window displaying the AMICO website. The browser's address bar shows the URL <http://www.amico.org/docs.html>. The website header features the AMICO logo and the text "Art Museum Image Consortium" and "Enabling Educational Access to Museum Multimedia Documentation". A vertical navigation menu on the left includes links for Home, Members, FAQ, AMICO library, Sample Records, Projects, Documents (highlighted), Contact, and Sponsors. The main content area is titled "Documents" and lists several links: [About AMICO](#), [Distribution of the AMICO Library](#), [AMICO Membership](#), [University Testbed Project](#), [AMICO Library Submissions](#), [Press Releases](#), [AMICO Library Subscriptions](#), and [Articles and Presentations](#). Below this, the "About AMICO" section contains links for [AMICO Mission Statement](#), [AMICO Members](#), [Diagram of the AMICO process, July 1998](#), and [AMICO's ByLaws \(download a .PDF file\)](#). The "AMICO Membership" section lists [Membership is Open](#), [AMICO Membership: Summary of Benefits and Obligations](#), [AMICO Full Membership Application \(.PDF file\)](#), [AMICO Associate Membership Application \(.PDF file\)](#), [AMICO Full Membership Agreement \(.PDF file\)](#), and [AMICO Associate Membership Agreement \(.PDF file\)](#). The "AMICO Library Submissions" section includes [AMICO Data Specification](#) (with sub-links for [Text Record Specification, Version 1.0](#), [Related Image and Multimedia File Specification, Version 1.0](#), and [AMICO Data Dictionary, Version 1.2](#)) and [Sample Records](#). Finally, the "AMICO Library Subscriptions" section lists [General AMICO Subscription Information](#), [AMICO Library University Agreement \(.PDF file\)](#), [AMICO Library Short University Agreement \(.PDF file\)](#), and [AMICO Library Museum Agreement \(.PDF file\)](#).

# Management

Membership led:  
Board comprised of members' directors

- **Chairman**
  - Harry S. Parker III, Fine Arts Museum of San Francisco
- **Secretary**
  - Malcolm R. Rogers, Boston Museum of Fine Art
- **Treasurer**
  - Maxwell L. Anderson, Whitney Museum of American Art
- **Executive Director**
  - Jennifer Trant
- **Recruiting now!**
  - Library Editor
  - Technical Director
  - see [www.amico.org](http://www.amico.org) for job postings